

**UNIVERSITY COLLEGE TATI (UC TATI)****FINAL EXAMINATION QUESTION BOOKLET**

COURSE CODE	: DTM 2023
COURSE	: SOLID MECHANICS
SEMESTER/SESSION	: 1- 2024/2025
DURATION	: 3 HOURS

Instructions:

1. This booklet contains 4 questions. Answer **ALL** questions.
2. All answers should be written in answer booklet.
3. Write and Sketch legibly wherever required.
4. Question booklet need to be returned after session ends.
5. If in doubt, raise your hand and ask the invigilator.

DO NOT OPEN THIS BOOKLET UNTIL YOU ARE TOLD TO DO SO

THIS BOOKLET CONTAINS 6 PRINTED PAGES INCLUDING COVER PAGE

A small, handwritten mark or signature in the bottom right corner of the page.

QUESTION 1

- a) **Compute** force required to punch a 20 mm-diameter hole in a plate that is 25 mm thick. The shear strength is 350 MN/m². (6 marks)
- b) A bar 500 mm long and 10 mm in diameter is elongated by 5 mm under the effect of axial pull of 50 kN. **Compute:**
- i. stress, (3 marks)
 - ii. strain and (3 marks)
- c) Two gage marks are placed exactly 250 mm apart on a 12 mm diameter aluminum rod with $E = 73$ GPa and an ultimate strength of 140 MPa. Knowing that the distance between the gage marks is 250.28 mm after a load is applied, **Compute:**
- i. the stress in the rod (5 marks)
 - ii. the factor of safety. (3 marks)

QUESTION 2

A shaft composed of segments Bronze (AB), Aluminium (BC), and Steel (CD) are fastened to rigid supports and loaded as shown in Figure 1. The diameter of the shaft is 50mm. For bronze, $G = 35 \text{ GPa}$; aluminum, $G = 28 \text{ GPa}$, and for steel, $G = 83 \text{ GPa}$.

Compute :

- i. The torque graph of the shaft (3 marks)
- ii. The maximum shear stress in shaft AB. (3 marks)
- iii. The maximum shear stress in shaft BC. (3 marks)
- iv. The maximum shear stress in shaft CD. (3 marks)
- v. The angle of twist of shaft AB. (3 marks)
- vi. The angle of twist of shaft BC. (3 marks)
- vii. The angle of twist of shaft CD. (3 marks)
- viii. Total angle of twist at end A. (4 marks)

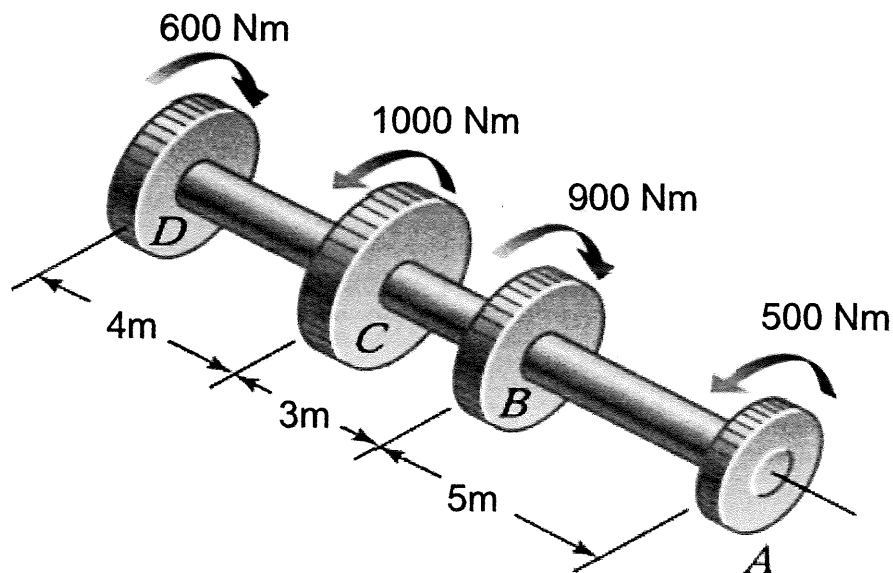

Figure 1

QUESTION 3

According to Figure 2, the beam is loaded with load at point A-C and D. The beam can afford the maximum stress of 200 MPa. You need to provide the following information:

- i. **Sketch** the free body diagram (2 marks)
- ii. **Compute** the reaction values at both supports. (3 marks)
- iii. **Construct** the shear force diagram for the beam. (6 marks)
- iv. **Construct** the bending moment diagram for the beam (15 marks)
- v. **Compute** the maximum bending moment for the beam (4 marks)

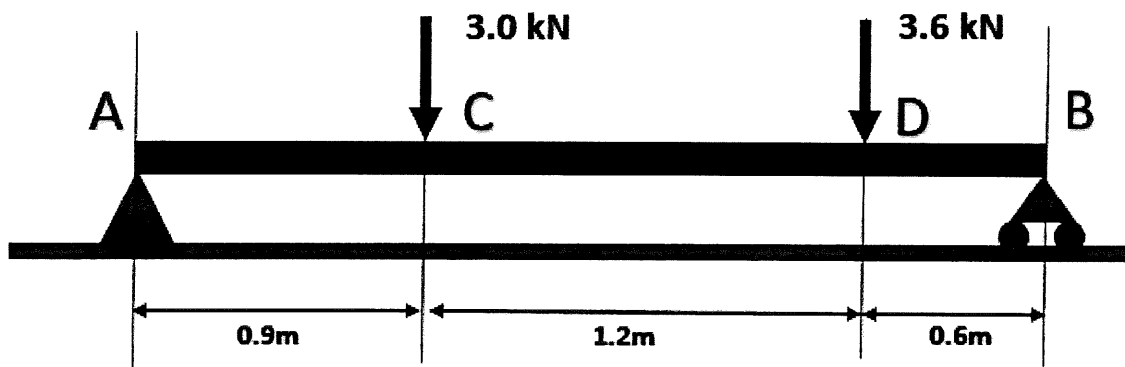

Figure 2

QUESTION 4

According to Figure 3, you need to provide some information due to deflection and slope problem. Given that the cross section of the beam is 300 mm x 50 mm and Modulus of Elasticity (E) is 120 GPa,

- i. **Compute** the moment of inertia of the cross section (3 Marks)
- ii. **Construct** the Deflection formula of the beam (7 Marks)
- iii. **Construct** the Slope formula of the beam (7 Marks)
- iv. **Solve** the Slope at end A (4 Marks)
- v. **Solve** the Deflection at C (4 Marks)

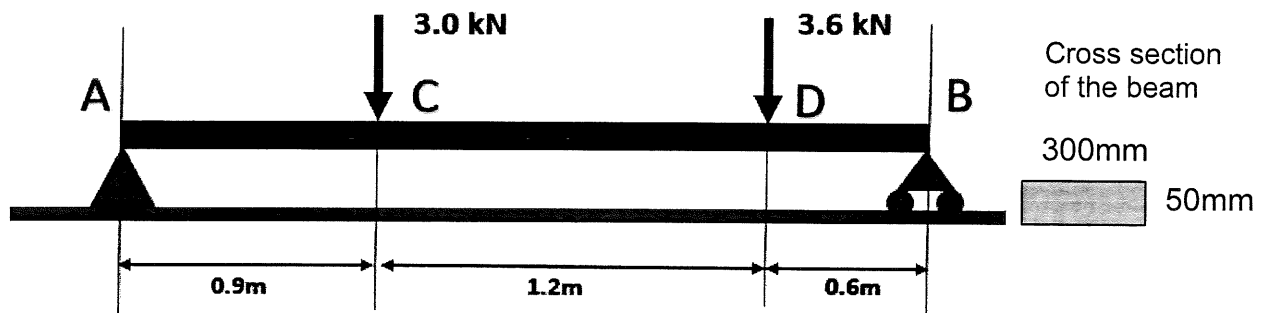

Figure 3

-----end of questions-----

FORMULA**Stress Strain**

Normal stress

$$\sigma = \frac{F}{A}$$

Shear stress

$$\tau = \frac{F}{A}$$

double shear

$$\tau = \frac{F}{2A}$$

Modulus of Elasticity $E = \frac{FL}{Ax}$ **Torsion**

$$\frac{T}{J} = \frac{G\theta}{L} = \frac{\tau}{R}$$

Polar second moment of area

$$J_{solid\ shaft} = \frac{\pi D^2}{32} \quad J_{hollow\ shaft} = \frac{\pi}{32}(D^2 - d^2)$$

Shear Force and Bending Moment

Interpolation

$$Vb - Va = -wx$$

Deflection of Beam

$$EI \frac{d^2y}{dx^2} = M(x)$$

$$Slope = \frac{dy}{dx} = \theta(x)$$

$$deflection = y(x)$$